

TP-P001 | MULTI LANE STICKPACK MACHINE FOR POWDERY PRODUCT

TURPACK
www.turpack.com



This fully automatic filling machine is designed to pack untouched, affixed-on-three-sides packets like coffee, coffee cream, energy drinks, medical powder that has no spontaneous fluency through screws by disposable products. Non free flowing powder products can be packaged with this machine using screws synchronized with PLC in a high level of sensitivity. The machine can produce 100 pcs/min using 3 channels and 350 pcs/min using 10 channels.

Technical Specifications

Number Of Lanes	3 to 12 Lanes (Depending on Stick Width)
Filling Weight Range	(0,25-1 gr) (1-5 gr) (5-20 gr) (20-50 gr)
Bag Width	25 - 65 mm
Bag Length	170 mm (adjustable), max 200 mm for special packs
Capacity	30-35 Sticks/min/Lane (Max 420 pcs/min)
Filling System	Auger Dosing
Servo Motor	KOLLMORGEN
Control System	SIEMENS PLC
Pneumatic System	FESTO
Sensor	SICK
Construction Body	SS304
Parts In Product Contact	SS316
Package Style Format	3 Side Seal
Maximum Roll Width	800 mm Max.
Maximum Roll Diameter	450 mm Max.
Compressed Air Cons.	6 Bar, (MAX 450 Litres/min)
Weigth of the Machine	750 kg
Electricity Connection	Can be produced according to your country's connection system.
Power Consumption	10 KW
Package Specification	12 PET, 7 AL, 35-60 PE
Application	Non free flowing products 3 in 1 coffee, coffee cream, powdery chemincals, protein powder; etc.
Optional Features	Date Coding System Additional Servo Motor Conveyor Belt Easy Open Side Tear Notch Perforation Auto Feeding System

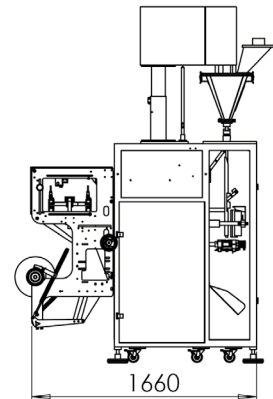
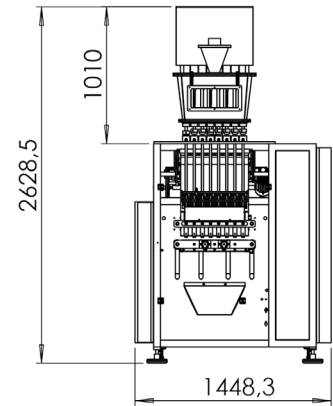

SUITABLE FOR

Packing non free flowing products, such as classic coffee, gold coffee, coffee cream, 3in1 instant coffee, powdery chemicals etc.



Dimensions, weight, power usage and technical drawings are for the machine in the picture. There may be slight variations for different machines.