

TP-L401 | MULTI LANE SACHET MACHINE FOR LIQUID PRODUCTS

TURPACK
www.turpack.com



This fully automatic packaging machine is designed to prepare sachet type packages (affixed on 4 sides) and to place untouched liquid products. Ketchup, mayonnaise, mustard, olive oil, liquid soap, shampoo, water, conditioner, gel and similar liquid and gel-like products can be packaged with these precise pumps. Four side seal sachet packaging machine for liquid and paste of products with many customer reference of major food, cosmetic and pharmaceutical manufacturers. High weight accuracy, excellent seal integrity to protect filled product. Machine can run with high speed of 90-240 sachets depending on number of filling lanes. 4 side sealed sachet machine can be customized up from 3 to 8 lanes to form different shapes of sachet pouches.

Technical Specifications

Number Of Lanes	3-10 Lanes (Depending on Sachet Width)
Filling Weight Range	(2-10 ml) (10-20 ml) (20-50 ml) (50-100 ml)
Bag Width	Between 40mm to 120mm (Depending on the Max Roll Width)
Bag Length	Max 150 mm (adjustable)
Capacity	30-35 Sachets/min/Lane (Max 350 pcs/min)
Filling System	Servo Motor Driven Liquid Pump
Servo Motor	KOLLMORGEN
Control System	SIEMENS PLC
Pneumatic System	FESTO
Sensor	SICK
Construction Body	SS304
Parts In Product Contact	SS316
Package Style Format	4 side Seal Sachet
Maximum Roll Width	800 mm Max.
Maximum Roll Diameter	450 mm Max.
Compressed Air Cons.	6 Bar, (MAX 450 Litres/min)
Weight of the Machine	875 kg
Electricity Connection	Can be produced according to your country's connection system.
Power Consumption	10 KW
Package Specification	12 PET, 7 AL, 35-60 PE
Application	Liquid and paste products: ketchup, mayonnaise, honey, olive oil, vinegar, salad souces, mustard, liquid cosmetic products, etc.

Optional Features

Date Coding System
Conveyor Belt
Notch For Sachet Machine
Guillotine Notch For Sachet Machine
Perforation
Liquid Pump (Food Graded)

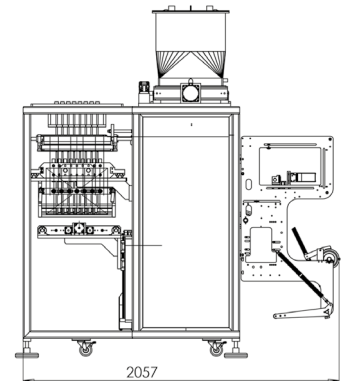
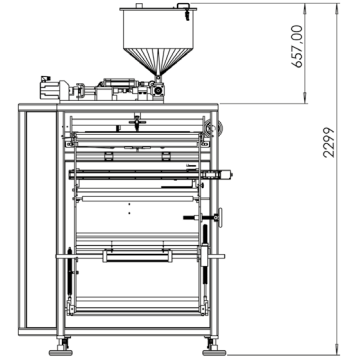

SUITABLE FOR

Packing liquid and paste products, like ketchup, mayonnaise, mustard, honey, and liquid gel cosmetics such as shampoo, liquid soap etc.



Dimensions, weight, power usage and technical drawings are for the machine in the picture. There may be slight variations for different machines.