

TP-HL001 | HORIZONTAL FFS (Form, Fill, Seal) MACHINE FOR LIQUID PRODUCTS

TURPACK
www.turpack.com



Horizontal Liquid Filling Machines allow fluid and dense liquids to be packed as the desired milli-grams into disposable sachets which are filled and sealed as 4 Sides Sachets. The fully automatic horizontal liquid filling machines are the most suitable solutions for food packing, especially cosmetics, chemistry, medicine, cleaning and so on .. The sachet widths are flexible. Both the width and height of the sachets can be changed depending on demand, this gives the customer a flexible usage.

Technical Specifications

Number Of Lanes	Single Lane
Filling Weight Range	(1-5 ml) (5-20 ml) (20-70 ml)
Bag Width	50x50 mm
Bag Length	150x150 mm
Capacity	Max 90 pcs/min (Depends on Product)
Filling System	Servo Motor Driven Liquid Pump
Servo Motor	KOLLMORGEN
Control System	SIEMENS PLC
Pneumatic System	FESTO
Sensor	SICK
Construction Body	SS304
Parts In Product Contact	SS316
Package Style Format	4 side Seal Sachet
Maximum Roll Width	300 mm Max.
Maximum Roll Diameter	450 mm Max.
Compressed Air Cons.	6 Bar, (MAX 450 Litres/min)
Weight of the Machine	650 Kgs
Electricity Connection	Can be produced according to your country's connection system.
Power Consumption	10 KW
Package Specification	12 PET, 7 AL, 35-60 PE
Application	Suitable for packing liquid and paste products, like ketchup, mayonnaise, mustard, honey, and liquid gel cosmetics such as shampoo, liquid soap etc.

Optional Features

- Additional Tank For Fill Powder
- Additional Servo Motor
- Date Coding System
- Conveyor Belt
- Easy Open Side Tear Notch
- Perforation
- Liquid Pump (Food Graded)

SUITABLE FOR

Packing liquid and paste products, like ketchup, mayonnaise, mustard, honey, and liquid gel cosmetics such as shampoo, liquid soap etc.

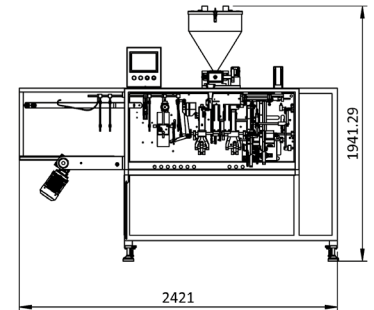
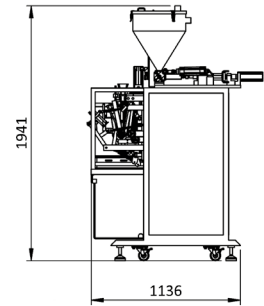

Dimensions, weight, power usage and technical drawings are for the machine in the picture. There may be slight variations for different machines.