

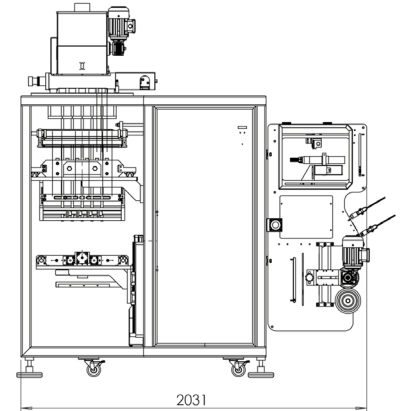

This fully automatic packaging machine that is designed to prepare a 4 side sealed sachet-type packages to fill free flowing granular products like sugar, salt, and spices like free flow black pepper. Products that have self-flowability like sugar, salt, black pepper and other medical grained granules can be packaged through precise volumetric cups using this model. This machine can produce 60 pcs/min using with 2 channels and 180 pcs with 6 channels.

## Technical Specifications

Number Of Lanes	1-10 Lanes (Depending on Sachet Width)
Filling Weight Range	(3-6 gr Sugar) (0.7-2 gr Salt) (0.25-1 gr Black Peper)
Bag Width	Between 40mm to 120mm (Depending on the Max Roll Width)
Bag Length	Max 150 mm (adjustable)
Capacity	30-35 Sachets/min/Lane (Max 350 pcs/min)
Filling System	Volumetric Cup Filler
Servo Motor	KOLLMORGEN
Control System	SIEMENS PLC
Pneumatic System	FESTO
Sensor	SICK
Construction Body	SS304
Parts In Product Contact	SS316
Package Style Format	4 Side Seal Sachet
Maximum Roll Width	800 mm Max.
Maximum Roll Diameter	450 mm Max.
Compressed Air Cons.	6 Bar, (MAX 450 Litres/min)
Weigth of the Machine	760 kg
Electricity Connection	Can be produced according to your country's connection system.
Power Consumption	10 KW
Package Specification	Sugar: 50-60 Paper, 15 PE - Salt: 65 Paper, 12 PE
Application	Free Flowing Products: sugar, salt, black pepper etc.
Optional Features	Date Coding System Conveyor Belt Notch For Sachet Machine Guillotine Notch For Sachet Machine Perforation Auto Feeding System

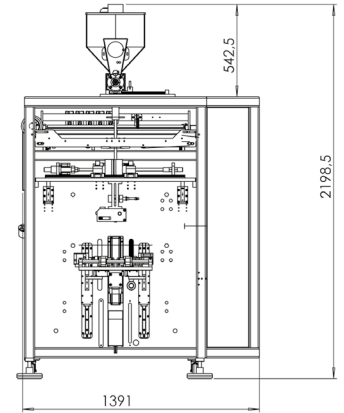

## SUITABLE FOR

Packing free flowing products such as sugar, salt, black pepper etc.



*Dimensions, weight, power usage and technical drawings are for the machine in the picture. There may be slight variations for different machines.*